

CLASS 125

IRON BALL VALVE (Full Port)

120°C Non-shock water 1.37MPa, 120°C Water, oil, gas 0.98MPa
Saturated steam 0.69MPa

Fig. 125FCTB



Blowout-proof stem

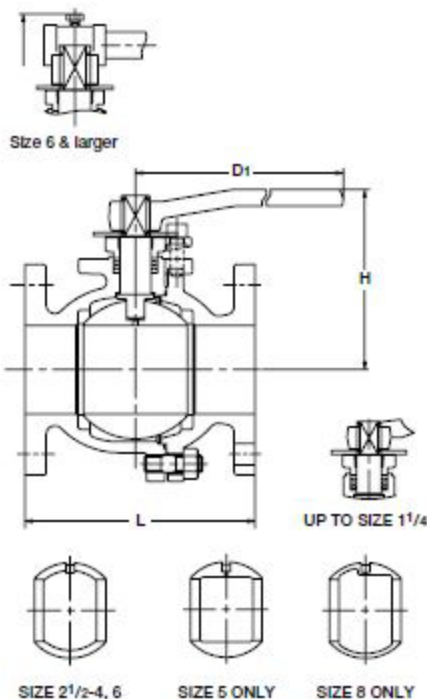

Materials

Parts	Material	JIS Spec.
Body	Cast Iron	A126 CL. B
Body cap	Cast Iron	A126 CL. B
Stem	Stainless Steel	A276 Type403
Ball	Stainless Steel	A276 Type 304 or A312 Gr.TP304 or A351 Gr.CF8
Grand packing		PTFE
Gasket		PTFE
Ball Seat		PTFE
Cap bolt		Carbon Steel
Handle		Ductile Iron

Design Specifications

Items	
Shell wall thickness and general valve design	KITZ Standard
Face-to-face dimensions End-to-end dimensions	ASME B16.10 Class150
End flange dimensions Gasket contact facing	ASME B16.1 Class125

Dimensions

Valve Size	inch mm	2	2 1/2	3	4	6	8	mm
L Face-to-face		178	190	203	229	394	457	
H Height		120	155	165	200	295	355	
D Handle		230	400	400	460	1000	1500	