

TYPE 400

3-WAY BRASS BALL VALVE

Screwed body cap, 2-seat, L-port design,
Blowout-proof Stem, Double O-ring stem seals*
Threaded ends to BS21 or NPT, or solder joint ends.

W.O.G. non-shock 2.76 MPa (400 psi), W.O.G. 150°C 0.69 MPa (100 psi)

*Size 1/2 and larger



Fig. TN

- Threaded end to BS21

Fig. AKTN

- Threaded end to ASME B1.20.1

Fig. CTN

- Solder joint end to ASME B16.18
- CTN 1/2 to 2

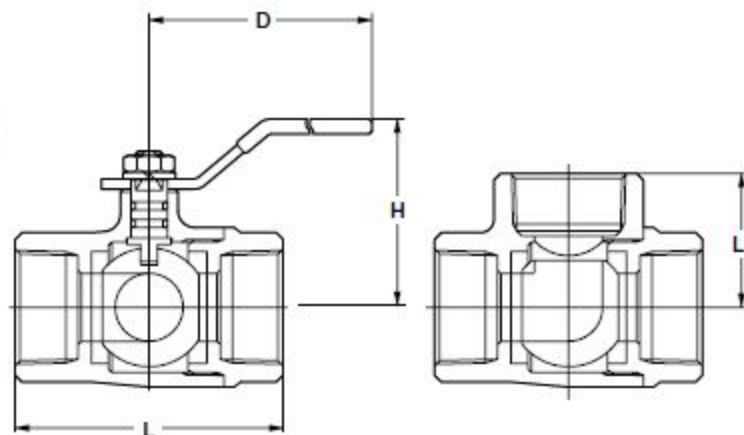

Dimensions

Nominal Size	mm										
	Inch	1/4	3/8	1/2	3/4	1	1 1/4	1 1/2	2	2 1/2	3
L Threaded end to end	40	46	67	68	79	89	100	115	138	166	
L1 Solder				56	74	88	99	114	136		
H Height	30	34	45	48	55	60	65	75	91	105	
H1 Height solder				45	48	55	60	65	75		
D Length of Handle	60	70	80	80	110	110	110	140	200	300	

Port position fig: Position 1 & 2

Materials

*Size 2 1/2 and 3

Parts	Material
Body	Brass/Bronze*
Body cap	Brass
Stem	Dezincification Resistant Brass
Ball	Brass**
Ball seat	PTFE
O-ring	FKM

**Chrome or Nickel-chrome plated

Caution

Solder joint end valves should not be used in service where the temperature of line fluid is higher than the softening point of solder.